



The Encodalizer™

Model PTE Pulse-to-Encoder Version



AWWA C707-05 COMPLIANT
2 YEAR WARRANTY

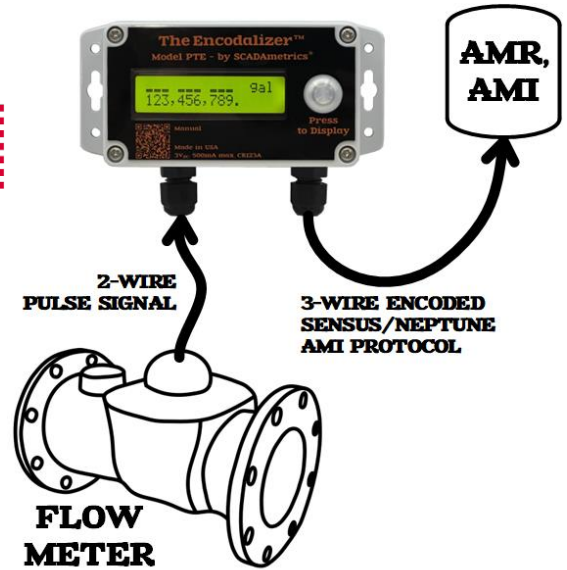

AMI Gateway and Remote Display for Pulse-Output Flow Meters!...

The Encodalizer™ – Do you have a pulse-capable flow meter that you would like to connect to an AMI network (fixed-base, cellular, drive-by), but it does not have a 3-wire encoded output?

The Encodalizer provides the solution! – as it can accept a generic, pulse-per-volume input signal, and convert into a 3-wire, encoded output!

Furthermore, the encoded output is user-selectable as either **Sensus Protocol** (4-9 digits) or **Neptune Protocol** (6 or 8 digits). These protocols form the de facto standards for water AMI connectivity throughout North America.

Pulse-Input flow meter types:

- **Wastewater Meters**
- **Magnetic Flow Meters**
- **Venturi Meters**
- **Weir Meters**
- **Parshall Flume Meters**
- **Turbine & Propeller Meters**
- **Ultrasonic Meters**
- **Positive Displacement Meters**

Key Features -

- **Converts Meter Pulse Signal to 3-Wire Encoded Signal: Sensus and Neptune AMI Protocols**
- **Accepts Most Dry-Contact Pulse Meters (Reed Relay, Open-Collector, Open-Drain). Does NOT Accept Voltage Pulses.**
- **Easy Setup via Dip Switches! – No Programming Required!**
- **Battery-Powered
Battery Life Up to 10+ Years (Depends Upon Usage)**
- **For Outdoor or Indoor Use. Wall-Mountable.
Built to NEMA-4X, IP-66 Specifications.
Not Submersible**
- **Large, 2x16 Character Backlit Display**
- **Pulse Synchronization Feature**
- **Displays Registration Units**
- **Battery Voltage Display**

Are you interested in learning more about how SCADAMetrics gateway technology can help connect more and varied flow meters to your district-wide AMI system? Give us a call! We'll be glad to discuss the details!

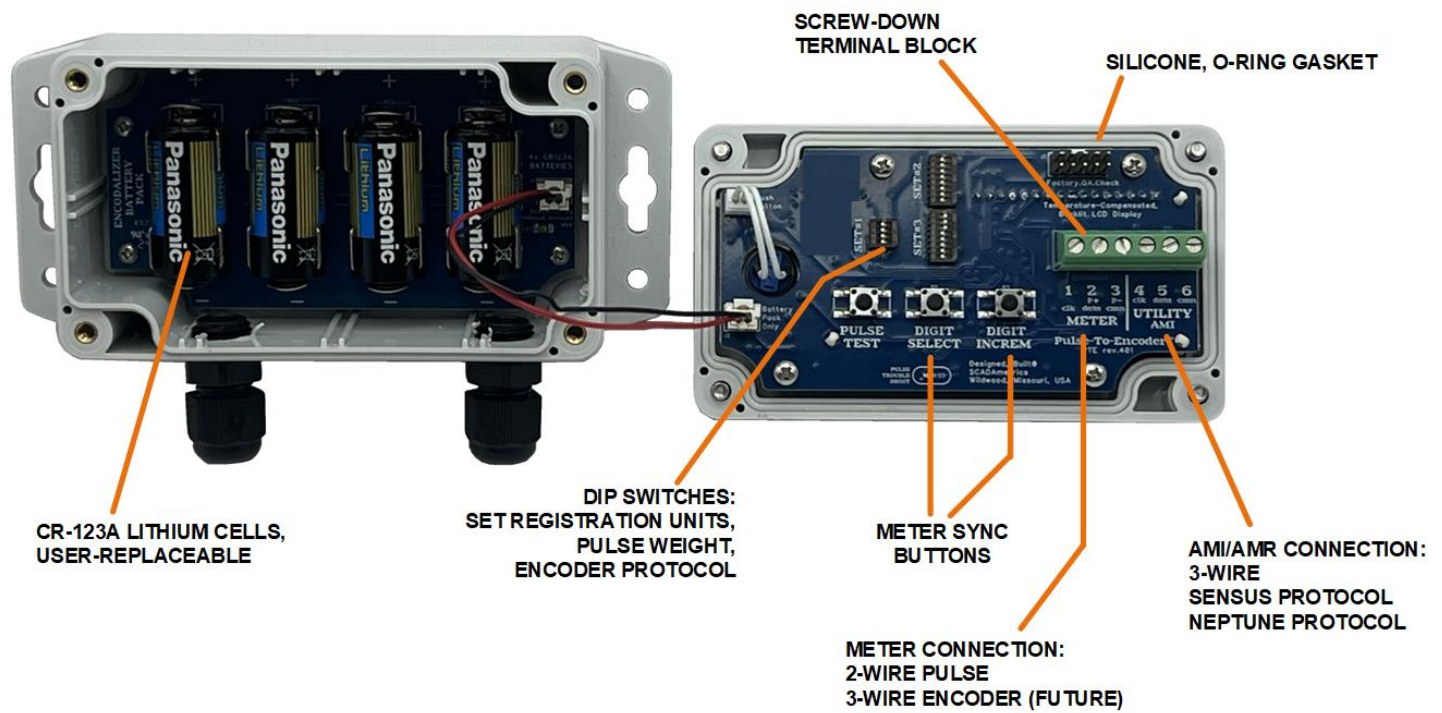

Engineering Specifications -

Dimensions:	5.75" x 3.50" x 2.25"
Weight:	8.5 Ounces
Physical Display:	2x16 Characters, Temperature-Compensated, Character Dimension: 0.114 x 0.203 inch
Displayed Metering Data:	Meter Totalization, with Encoded Digits Highlighted with Overlines
Displayed Battery Status:	Volts (New Battery ~ 3.2V _{DC} , Depleted Battery ~ 2.2V _{DC})
AMI Output Port:	Yes, Supports 3-Wire AMI Devices
Input Meter Connection:	3-Position, Screw-Down Terminal Block, 12-26 AWG
AMI Output Connection:	3-Position, Screw-Down Terminal Block, 12-26 AWG
Programming Method:	Integrated DIP Switches (20). No External Programming Device Required.
Supported Units:	Gallon, Cubic Feet, Cubic Meters, Liters, Acre-Feet, Generic "Units"
Supported Pulse Inputs:	Reed-Relay, Open-Collector, Open-Drain
Supported Pulse Weights:	x1, x10, x100, x1,000, x0.1, x0.01, x0.001, x0.0001, x0.05, x0.5, x5, x50, x500
Sensus Protocol Support:	Yes, Variable Digit Sensus Protocol (4-9 digits)
Neptune Protocol Support:	Yes, Both 8-Digit "E-Coder Plus", and 6-Digit "Pro-Read" Protocols
Temperature:	-20C to 70C (-4°F to 158°F)
Relative Humidity:	5% to 95%, Non-Condensing
Enclosure Rating:	Built to NEMA-4X and IP-68 Specifications, Not Rated for Submersion
Push-Button Rating:	Built to IP68 Specifications
Manufacturing Location:	USA
Environmental:	ROHS-Compliant, Lead-Free
Meter Interface:	AWWA C707-05
Display Integrity Check:	Yes - Pixel Test Pattern Displayed
Internal Desiccant Pack:	Yes - Silica Gel, 5gm
Sealing Plug:	Yes - 1/4" NPT Plug. Replaces 2 nd Cable Gland If AMI Output Port Not Used.
Warranty:	2 Years (see www.scadametrix.com for details)
Battery:	4x Energizer CR123A (1500mAh) or Panasonic CR123A (1550mAh), User-Replaceable
Mains Power Supply:	Not Supported

Sample Screenshots -



Gallon Registration



Liter Registration



Pre-Load Meter Reading



K-Gallon Registration



M³ Registration



Splash Screen



FT³ Registration



Acre-Foot Registration

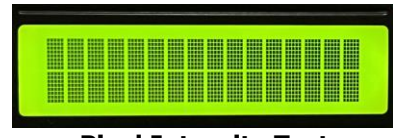

Pixel Integrity Test



K-FT³ Registration



Generic Unit Registration



Battery Voltage Indication

Engineering Dimensions (Inches) -

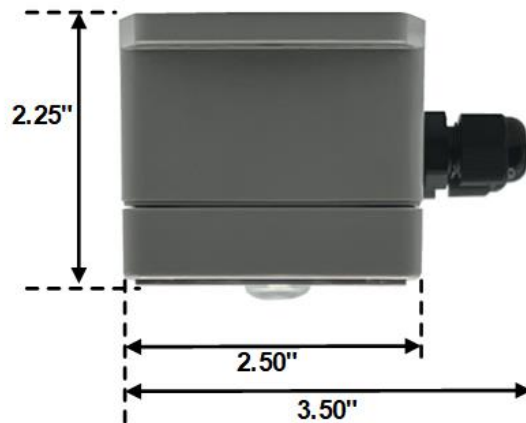
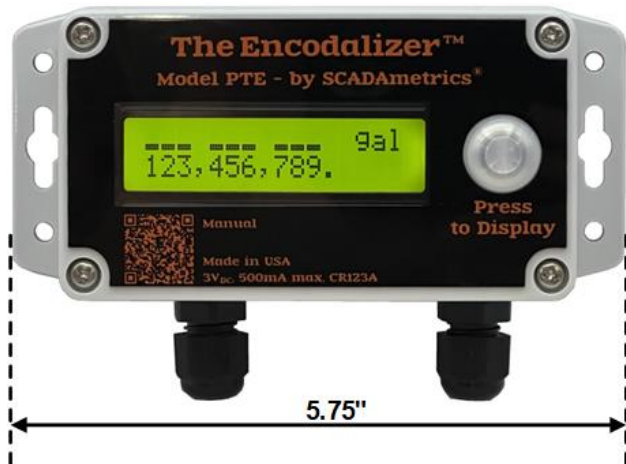

Pulse Input Meter Wiring -

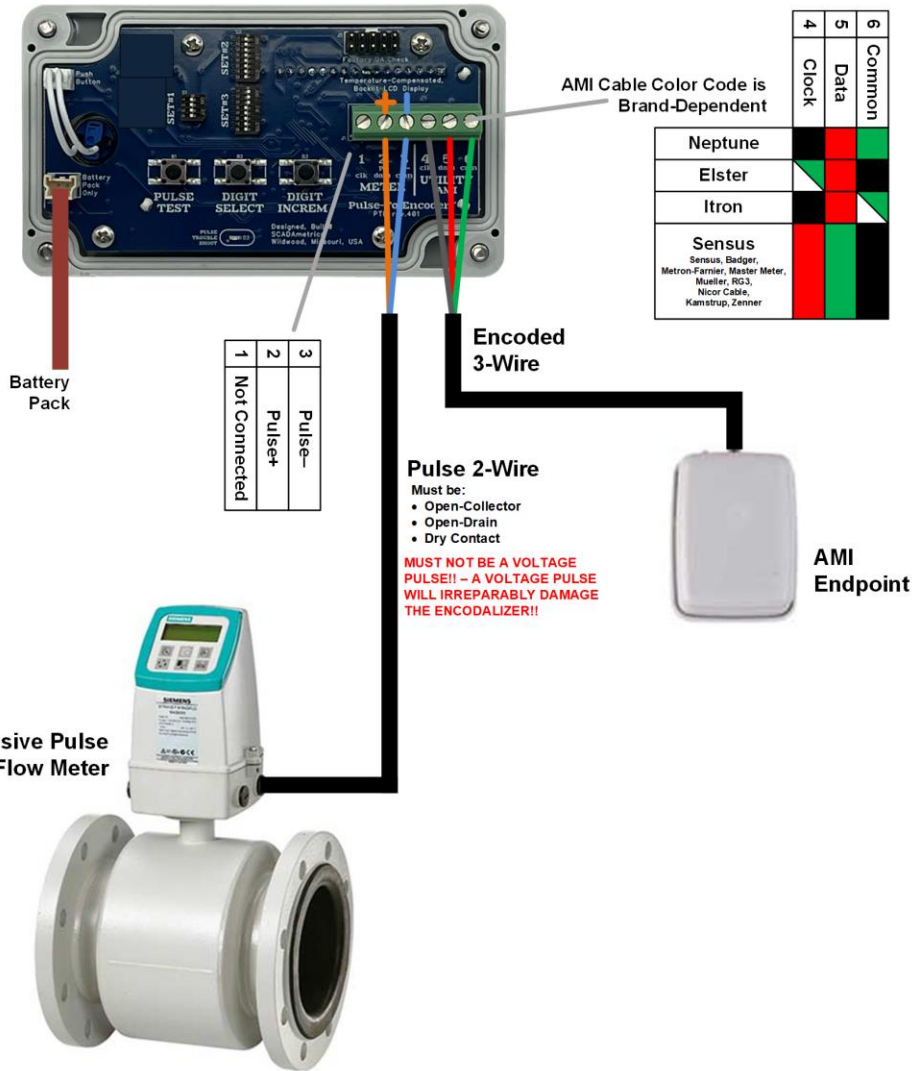

Wiring Notes:

1. Input Pulse **MUST BE** a No-Voltage / Dry-Contact-Type (Reed Relay, Open-Collector, or Open-Drain). The Input Pulse **MUST NOT BE** a Voltage Pulse, as this will cause irreparable damage to the Encodalizer. Such misuse is not covered under warranty.
2. Input Pulse **MUST NOT BE** Co-Connected in Parallel to Any Other Reading Device. If the Pulse Signal Needs to Be Shared, then a Pulse Splitting Device (such as the SCADAmetrics model APK) Must Be Used!
3. Color Codes for Clock, Data, and Common Vary by brand of AMI/AMR endpoint. See above table for details. Most (but not all) AMI/AMR manufacturers follow the Sensus wire color-coding scheme.

Flow Meter Settings -

1. Refer to User Manual for the Pulse-Output-Type Flow Meter.
2. Select an appropriate pulse weight (e.g. 1 kgal per pulse)
The number of pulses per day should average LESS THAN 1440 (less than 1 pulse per minute).
3. If the Flow Meter offers a setting for "pulse width", set to 100 milliseconds.

Encodalizer Dip Switch Setup -

1. There are 3 banks of DIP Switches: Set #1, Set #2, and Set #3.
2. A DIP Switch is deemed OFF when it is toggled to the LEFT.
3. A DIP Switch is deemed ON when it is toggled to the RIGHT.
4. Encodalizer Factory Default Settings are illustrated in YELLOW.
5. Future Features (Not Yet Implemented) are illustrated in GRAY.

TABLE KEY	
ENCODALIZER DEFAULT	
NOT YET IMPLEMENTED	
DIP SWITCH 'ON' (right)	ON →
DIP SWITCH 'OFF' (left)	← OFF

1. Upon initial installation, toggle DIP Switch SET #1.4 into the ON position to place the Encodalizer into **SETUP MODE**.
2. If the meter is a mechanical (reed-relay) pulse, then ENABLE the De-Bounce Filter feature by toggling the 1st DIP Switch of SET #1 into the ON position.
3. Set the **Input Meter Type** via DIP Switches SET #2: 1 thru 5. For example, for a pulse-type flow meter that transmits 1 pulse per 100 gallons, set DIP Switch 2 ON, and DIP Switches 1,3,4,5 to OFF.
4. Set the **Meter Registration Units**. This setting must match the registration units of the attached flow meter, and it is set via DIP Switches SET #2: 6 thru 8. For example, for a Cubic Foot registration meter, set DIP Switch 7 ON, and DIP Switches 6 and 8 OFF.
5. Set the **AMI Output Type**. This setting is via DIP Switches SET #3: 1 thru 3, and specifies the protocol type (Sensus or Neptune) and the number of transmitted totalizer digits. For example, to enable Sensus Protocol 8-digit, set DIP Switch #3 ON, and DIP Switches 1 and 2 OFF.
6. Set the **Truncated Least Significant Digits**. This setting is via DIP Switches SET #3: 4 and 5. For example, if the two (2) least significant digits should not be transmitted in the AMR message, then set DIP Switch 5 ON and 4 OFF.

SET #1		Enabled	Disabled
1	Weak De-Bounce Filter	ON	
2	Strong Pullup Resistor	ON	
3	Strong De-Bounce Filter	ON	
4	SETUP MODE	ON	

← **IMPORTANT !**
SETUP MODE = Toggled to Right
RUN MODE = Toggled to Left

Dip Switch Setup (cont) -

SET #2						Pulse x1	Pulse x10	Pulse x100	Pulse x1,000	Pulse x0.1	Pulse x0.01	Pulse x0.001	Pulse x0.0001	Pulse x0.05	Pulse x0.5	Pulse x5	Pulse x50	Pulse x500	Encoder Sensus (future)	Encoder Neptune (future)	Encoder Elster (future)					
1	Input Meter Type Part.1 of 2						<input checked="" type="checkbox"/>													<input checked="" type="checkbox"/>						
2								<input checked="" type="checkbox"/>																		
3									<input checked="" type="checkbox"/>																	
4										<input checked="" type="checkbox"/>									<input checked="" type="checkbox"/>							
5																				<input checked="" type="checkbox"/>						

SET #2						future	future	future	future	future	future	future	future	future	future	future	future	future	future	future	future					
1	Input Meter Type Part.2 of 2						<input checked="" type="checkbox"/>																			
2								<input checked="" type="checkbox"/>																		
3									<input checked="" type="checkbox"/>																	
4										<input checked="" type="checkbox"/>									<input checked="" type="checkbox"/>							
5																				<input checked="" type="checkbox"/>						

SET #2			Gallons	K-Gallons	FT ³	K-FT ³	Liters	M ³	AF (Acre-Ft)	Generic Units
6	Registration Units			<input checked="" type="checkbox"/>						<input checked="" type="checkbox"/>
7					<input checked="" type="checkbox"/>					<input checked="" type="checkbox"/>
8							<input checked="" type="checkbox"/>			

Dip Switch Setup (cont) -

SET #3		Sensus 4	Sensus 5	Sensus 6	Sensus 7	Sensus 8	Sensus 9	Neptune 6	Neptune 8
1	AMI Output Type		<input type="checkbox"/>		<input type="checkbox"/>		<input type="checkbox"/>		<input type="checkbox"/>
2				<input type="checkbox"/>	<input type="checkbox"/>			<input type="checkbox"/>	<input type="checkbox"/>
3						<input type="checkbox"/>	<input type="checkbox"/>	<input type="checkbox"/>	<input type="checkbox"/>

SET #3		No Truncation	Truncate 1 Digit	Truncate 2 Digits	Truncate 3 Digits
4	Truncated Least Significant Digits		<input type="checkbox"/>		<input type="checkbox"/>
5				<input type="checkbox"/>	<input type="checkbox"/>

SET #3		Enabled	Disabled	Comments
6	LCD Backlight	<input type="checkbox"/>		Disabled=Lowest Power
7	LED Blink Indicator	<input type="checkbox"/>		Disabled=Lowest Power
8	AMI Low Batt '?'	<input type="checkbox"/>		

QUICK-START GUIDE -

Physical Installation (Must Read!):

- 1. The Model PTE Encodalizer™ is designed as an indoor/outdoor device (but never submerged!), capable of being opened and re-sealed, thereby allowing for the user to protect the wiring and replace depleted batteries. With these capabilities also comes a heavy responsibility upon the user to properly re-seal the unit!**
- 2. Unit should be mounted on a wall or post, facing the user, and with the cable glands pointed down! (Why is this important?!)**
- 3. If the AMI output port is not used, the second cable gland should be replaced by the ¼" NPT plug seal!**
- 4. Do not install more than 1 jacketed cable within a single cable gland!**
- 5. Tighten the cable gland nut after installation to ensure a proper seal.**
- 6. Place the desiccant packs inside the unit before re-sealing! Do not throw them away!**
- 7. Improper installation or any evidence of moisture inside the unit voids the warranty.**
- 8. Whenever replacing the battery(s), ALL batteries must be replaced.**
- 9. Use common sense!**

Initial Setup – Pulse Meter Input:

1. Open Up the Encodalizer by Unscrewing the Four (4) Screws.
2. Insert the Input Pulse Cable Through the Left Cable Gland.
3. Land the 2 Pulse Wires on the Meter Terminal Block: 2(+), 3(-).

Input Pulse MUST BE a No-Voltage / Dry-Contact-Type (Reed Relay, Open-Collector, or Open-Drain). The Input Pulse MUST NOT BE a Voltage Pulse, as this will cause irreparable damage to the Encodalizer.

Input Pulse MUST NOT BE Co-Connected in Parallel to Any Other Reading Device. If the Pulse Signal Needs to Be Shared, then a Pulse Splitting Device (such as the SCADAmetrics model APK) Must Be Used!

Such misuse is not covered under warranty.

4. Place the SET#1 DIP Switch #4 into the ON Position (SETUP MODE).
5. Press the DISPLAY front button to wake up the unit.
6. Set all other DIP Switches, Per this Datasheet.
7. Pre-Load the Encodalizer to match the totalizer of the connected meter. This step is performed using the two internal buttons: DIGIT SELECT and DIGIT INCREMENT.

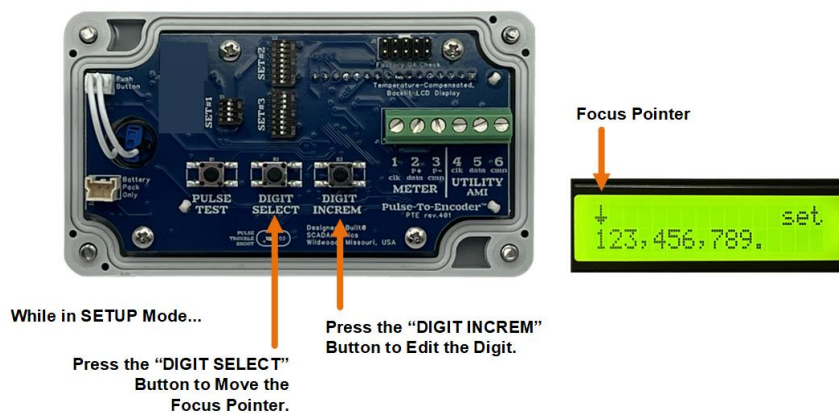

8. Place the SET#1 DIP Switch #4 into the OFF Position (RUN MODE).

AMI/AMR Connection:

1. Insert the AMI/AMR Cable Through the Right Cable Gland.
2. Land the 3 AMI/AMR Cable Wires on the Utility AMI Terminal Block (Terminals 4,5,6), Per Color-Coding Specified in this Datasheet.

Seal the Display:

1. Ensure that the Enclosed Desiccant Pack(s) is Inserted into the Base.
2. Attach the Cover to the Base by Evenly Tightening the Four (4) Screws.
3. Tighten the Cable Gland(s) (and ¼" NPT plug seal, for 1-cable installations).
4. State-Registered Service Agent Only: Affix the Two (2) Tamper-Evident Labels to the Left and Right Sides of the Display, Overlapping Both the Base and Cover.

Initial Setup – Encoded Meter Input:

1. Open Up the Encodalizer by Unscrewing the Four (4) Screws.
2. Insert the Input Encoded Cable Through the Left Cable Gland.
3. Land the 3 Encoded Input Wires on the Meter Terminal Block: 1 (Clock), 2 (Data), 3 (Cmn)

Input Encoded Cable MUST NOT BE Co-Connected in Parallel to Any Other Reading Device. If the Encoded Signal Needs to Be Shared, then a SCADAmetrics Model UDA Universal Duplexer Must Be Used!

4. Place the SET#1 DIP Switches {1,2,3,4} = {OFF,ON,OFF,ON}
 - Weak Debounce - Disabled
 - Strong Pullup - Enabled
 - Strong Debounce - Disabled
 - Setup Mode - Enabled
5. Press the DISPLAY front button to wake up the unit.
6. Set all other DIP Switches, Per this Datasheet.
7. Press the "DIGIT SELECT" Button to Align the Decimal Point to Match the Water Meter.
8. Place the SET#1 DIP Switch #4 into the OFF Position (RUN MODE).

AMI/AMR Connection:

1. Insert the AMI/AMR Cable Through the Right Cable Gland.
2. Land the 3 AMI/AMR Cable Wires on the Utility AMI Terminal Block (Terminals 4,5,6), Per Color-Coding Specified in this Datasheet.

Seal the Display:

1. Ensure that the Enclosed Desiccant Pack(s) is Inserted into the Base.
2. Attach the Cover to the Base by Evenly Tightening the Four (4) Screws.
3. Tighten the Cable Gland(s) (and 1/4" NPT plug seal, for 1-cable installations).
4. State-Registered Service Agent Only: Affix the Two (2) Tamper-Evident Labels to the Left and Right Sides of the Display, Overlapping Both the Base and Cover.

AMI and Display Tables -

Multiplier	Protocol	Truncate	AMI & Display
x1	Sensus.9	0	===== 1 2 3 4 5 6 7 8 9
x1	Sensus.8 Neptune.8	0	===== 1 2 3 4 5 6 7 8 9
x1	Sensus.7	0	===== 1 2 3 4 5 6 7 8 9
x1	Sensus.6	0	===== 1 2 3 4 5 6 7 8 9
x1	Sensus.5	0	===== 1 2 3 4 5 6 7 8 9
x1	Sensus.4	0	===== 1 2 3 4 5 6 7 8 9

Multiplier	Protocol	Truncate	AMI & Display
x10	Sensus.9	0	===== 1 2 3 4 5 6 7 8 0
x10	Sensus.8 Neptune.8	0	===== 1 2 3 4 5 6 7 8 0
x10	Sensus.7	0	===== 1 2 3 4 5 6 7 8 0
x10	Sensus.6	0	===== 1 2 3 4 5 6 7 8 0
x10	Sensus.5	0	===== 1 2 3 4 5 6 7 8 0
x10	Sensus.4	0	===== 1 2 3 4 5 6 7 8 0

Multiplier	Protocol	Truncate	AMI & Display
x100	Sensus.9	0	===== 1 2 3 4 5 6 7 0 0
x100	Sensus.8 Neptune.8	0	===== 1 2 3 4 5 6 7 0 0
x100	Sensus.7	0	===== 1 2 3 4 5 6 7 0 0
x100	Sensus.6	0	===== 1 2 3 4 5 6 7 0 0
x100	Sensus.5	0	===== 1 2 3 4 5 6 7 0 0
x100	Sensus.4	0	===== 1 2 3 4 5 6 7 0 0

Multiplier	Protocol	Truncate	AMI & Display
x1000	Sensus.9	0	===== 1 2 3 4 5 6 0 0 0
x1000	Sensus.8 Neptune.8	0	===== 1 2 3 4 5 6 0 0 0
x1000	Sensus.7	0	===== 1 2 3 4 5 6 0 0 0
x1000	Sensus.6	0	===== 1 2 3 4 5 6 0 0 0
x1000	Sensus.5	0	===== 1 2 3 4 5 6 0 0 0
x1000	Sensus.4	0	===== 1 2 3 4 5 6 0 0 0

Multiplier	Protocol	Truncate	AMI & Display
x1	Sensus.9	1	NOT VALID
x1	Sensus.8 Neptune.8	1	===== 1 2 3 4 5 6 7 8 9
x1	Sensus.7	1	===== 1 2 3 4 5 6 7 8 9
x1	Sensus.6	1	===== 1 2 3 4 5 6 7 8 9
x1	Sensus.5	1	===== 1 2 3 4 5 6 7 8 9
x1	Sensus.4	1	===== 1 2 3 4 5 6 7 8 9

Multiplier	Protocol	Truncate	AMI & Display
x10	Sensus.9	1	NOT VALID
x10	Sensus.8 Neptune.8	1	===== 1 2 3 4 5 6 7 8 0
x10	Sensus.7	1	===== 1 2 3 4 5 6 7 8 0
x10	Sensus.6	1	===== 1 2 3 4 5 6 7 8 0
x10	Sensus.5	1	===== 1 2 3 4 5 6 7 8 0
x10	Sensus.4	1	===== 1 2 3 4 5 6 7 8 0

Multiplier	Protocol	Truncate	AMI & Display
x100	Sensus.9	1	NOT VALID
x100	Sensus.8 Neptune.8	1	===== 1 2 3 4 5 6 7 0 0
x100	Sensus.7	1	===== 1 2 3 4 5 6 7 0 0
x100	Sensus.6	1	===== 1 2 3 4 5 6 7 0 0
x100	Sensus.5	1	===== 1 2 3 4 5 6 7 0 0
x100	Sensus.4	1	===== 1 2 3 4 5 6 7 0 0

Multiplier	Protocol	Truncate	AMI & Display
x1000	Sensus.9	1	NOT VALID
x1000	Sensus.8 Neptune.8	1	===== 1 2 3 4 5 6 0 0 0
x1000	Sensus.7	1	===== 1 2 3 4 5 6 0 0 0
x1000	Sensus.6	1	===== 1 2 3 4 5 6 0 0 0
x1000	Sensus.5	1	===== 1 2 3 4 5 6 0 0 0
x1000	Sensus.4	1	===== 1 2 3 4 5 6 0 0 0

Multiplier	Protocol	Truncate	AMI & Display
x1	Sensus.9	2	NOT VALID
x1	Sensus.8 Neptune.8	2	NOT VALID
x1	Sensus.7	2	===== 1 2 3 4 5 6 7 8 9
x1	Sensus.6	2	===== 1 2 3 4 5 6 7 8 9
x1	Sensus.5	2	===== 1 2 3 4 5 6 7 8 9
x1	Sensus.4	2	===== 1 2 3 4 5 6 7 8 9

Multiplier	Protocol	Truncate	AMI & Display
x10	Sensus.9	2	NOT VALID
x10	Sensus.8 Neptune.8	2	NOT VALID
x10	Sensus.7	2	===== 1 2 3 4 5 6 7 8 0
x10	Sensus.6	2	===== 1 2 3 4 5 6 7 8 0
x10	Sensus.5	2	===== 1 2 3 4 5 6 7 8 0
x10	Sensus.4	2	===== 1 2 3 4 5 6 7 8 0

Multiplier	Protocol	Truncate	AMI & Display
x100	Sensus.9	2	NOT VALID
x100	Sensus.8 Neptune.8	2	NOT VALID
x100	Sensus.7	2	===== 1 2 3 4 5 6 7 0 0
x100	Sensus.6	2	===== 1 2 3 4 5 6 7 0 0
x100	Sensus.5	2	===== 1 2 3 4 5 6 7 0 0
x100	Sensus.4	2	===== 1 2 3 4 5 6 7 0 0

Multiplier	Protocol	Truncate	AMI & Display
x1000	Sensus.9	2	NOT VALID
x1000	Sensus.8 Neptune.8	2	NOT VALID
x1000	Sensus.7	2	===== 1 2 3 4 5 6 0 0 0
x1000	Sensus.6	2	===== 1 2 3 4 5 6 0 0 0
x1000	Sensus.5	2	===== 1 2 3 4 5 6 0 0 0
x1000	Sensus.4	2	===== 1 2 3 4 5 6 0 0 0

Multiplier	Protocol	Truncate	AMI & Display
x1	Sensus.9	3	NOT VALID
x1	Sensus.8 Neptune.8	3	NOT VALID
x1	Sensus.7	3	NOT VALID
x1	Sensus.6	3	===== 1 2 3 4 5 6 7 8 9
x1	Sensus.5	3	===== 1 2 3 4 5 6 7 8 9
x1	Sensus.4	3	===== 1 2 3 4 5 6 7 8 9

Multiplier	Protocol	Truncate	AMI & Display
x10	Sensus.9	3	NOT VALID
x10	Sensus.8 Neptune.8	3	NOT VALID
x10	Sensus.7	3	NOT VALID
x10	Sensus.6	3	===== 1 2 3 4 5 6 7 8 0
x10	Sensus.5	3	===== 1 2 3 4 5 6 7 8 0
x10	Sensus.4	3	===== 1 2 3 4 5 6 7 8 0

Multiplier	Protocol	Truncate	AMI & Display
x100	Sensus.9	3	NOT VALID
x100	Sensus.8 Neptune.8	3	NOT VALID
x100	Sensus.7	3	NOT VALID
x100	Sensus.6	3	===== 1 2 3 4 5 6 7 0 0
x100	Sensus.5	3	===== 1 2 3 4 5 6 7 0 0
x100	Sensus.4	3	===== 1 2 3 4 5 6 7 0 0

Multiplier	Protocol	Truncate	AMI & Display
x1000	Sensus.9	3	NOT VALID
x1000	Sensus.8 Neptune.8	3	NOT VALID
x1000	Sensus.7	3	NOT VALID
x1000	Sensus.6	3	===== 1 2 3 4 5 6 0 0 0
x1000	Sensus.5	3	===== 1 2 3 4 5 6 0 0 0
x1000	Sensus.4	3	===== 1 2 3 4 5 6 0 0 0

Multiplier	Protocol	Truncate	AMI & Display
x0.1	Sensus.9	0	===== 1 2 3 4 5 6 7 8 . 9
x0.1	Sensus.8 Neptune.8	0	===== 1 2 3 4 5 6 7 8 . 9
x0.1	Sensus.7	0	===== 1 2 3 4 5 6 7 8 . 9
x0.1	Sensus.6	0	===== 1 2 3 4 5 6 7 8 . 9
x0.1	Sensus.5	0	===== 1 2 3 4 5 6 7 8 . 9
x0.1	Sensus.4	0	===== 1 2 3 4 5 6 7 8 . 9

Multiplier	Protocol	Truncate	AMI & Display
x0.01	Sensus.9	0	===== 1 2 3 4 5 6 7 . 8 9
x0.01	Sensus.8 Neptune.8	0	===== 1 2 3 4 5 6 7 . 8 9
x0.01	Sensus.7	0	===== 1 2 3 4 5 6 7 . 8 9
x0.01	Sensus.6	0	===== 1 2 3 4 5 6 7 . 8 9
x0.01	Sensus.5	0	===== 1 2 3 4 5 6 7 . 8 9
x0.01	Sensus.4	0	===== 1 2 3 4 5 6 7 . 8 9

Multiplier	Protocol	Truncate	AMI & Display
x0.001	Sensus.9	0	===== 1 2 3 4 5 6 . 7 8 9
x0.001	Sensus.8 Neptune.8	0	===== 1 2 3 4 5 6 . 7 8 9
x0.001	Sensus.7	0	===== 1 2 3 4 5 6 . 7 8 9
x0.001	Sensus.6	0	===== 1 2 3 4 5 6 . 7 8 9
x0.001	Sensus.5	0	===== 1 2 3 4 5 6 . 7 8 9
x0.001	Sensus.4	0	===== 1 2 3 4 5 6 . 7 8 9

Multiplier	Protocol	Truncate	AMI & Display
x0.0001	Sensus.9	0	===== 1 2 3 4 5 . 6 7 8 9
x0.0001	Sensus.8 Neptune.8	0	===== 1 2 3 4 5 . 6 7 8 9
x0.0001	Sensus.7	0	===== 1 2 3 4 5 . 6 7 8 9
x0.0001	Sensus.6	0	===== 1 2 3 4 5 . 6 7 8 9
x0.0001	Sensus.5	0	===== 1 2 3 4 5 . 6 7 8 9
x0.0001	Sensus.4	0	===== 1 2 3 4 5 . 6 7 8 9

Multiplier	Protocol	Truncate	AMI & Display
x0.1	Sensus.9	1	NOT VALID
x0.1	Sensus.8 Neptune.8	1	===== 1 2 3 4 5 6 7 8 . 9
x0.1	Sensus.7	1	===== 1 2 3 4 5 6 7 8 . 9
x0.1	Sensus.6	1	===== 1 2 3 4 5 6 7 8 . 9
x0.1	Sensus.5	1	===== 1 2 3 4 5 6 7 8 . 9
x0.1	Sensus.4	1	===== 1 2 3 4 5 6 7 8 . 9

Multiplier	Protocol	Truncate	AMI & Display
x0.01	Sensus.9	1	NOT VALID
x0.01	Sensus.8 Neptune.8	1	===== 1 2 3 4 5 6 7 . 8 9
x0.01	Sensus.7	1	===== 1 2 3 4 5 6 7 . 8 9
x0.01	Sensus.6	1	===== 1 2 3 4 5 6 7 . 8 9
x0.01	Sensus.5	1	===== 1 2 3 4 5 6 7 . 8 9
x0.01	Sensus.4	1	===== 1 2 3 4 5 6 7 . 8 9

Multiplier	Protocol	Truncate	AMI & Display
x0.001	Sensus.9	1	NOT VALID
x0.001	Sensus.8 Neptune.8	1	===== 1 2 3 4 5 6 . 7 8 9
x0.001	Sensus.7	1	===== 1 2 3 4 5 6 . 7 8 9
x0.001	Sensus.6	1	===== 1 2 3 4 5 6 . 7 8 9
x0.001	Sensus.5	1	===== 1 2 3 4 5 6 . 7 8 9
x0.001	Sensus.4	1	===== 1 2 3 4 5 6 . 7 8 9

Multiplier	Protocol	Truncate	AMI & Display
x0.0001	Sensus.9	1	NOT VALID
x0.0001	Sensus.8 Neptune.8	1	===== 1 2 3 4 5 . 6 7 8 9
x0.0001	Sensus.7	1	===== 1 2 3 4 5 . 6 7 8 9
x0.0001	Sensus.6	1	===== 1 2 3 4 5 . 6 7 8 9
x0.0001	Sensus.5	1	===== 1 2 3 4 5 . 6 7 8 9
x0.0001	Sensus.4	1	===== 1 2 3 4 5 . 6 7 8 9

Multiplier	Protocol	Truncate	AMI & Display
x0.1	Sensus.9	2	NOT VALID
x0.1	Sensus.8 Neptune.8	2	NOT VALID
x0.1	Sensus.7	2	===== 1 2 3 4 5 6 7 8 . 9
x0.1	Sensus.6	2	===== 1 2 3 4 5 6 7 8 . 9
x0.1	Sensus.5	2	===== 1 2 3 4 5 6 7 8 . 9
x0.1	Sensus.4	2	===== 1 2 3 4 5 6 7 8 . 9

Multiplier	Protocol	Truncate	AMI & Display
x0.01	Sensus.9	2	NOT VALID
x0.01	Sensus.8 Neptune.8	2	NOT VALID
x0.01	Sensus.7	2	===== 1 2 3 4 5 6 7 . 8 9
x0.01	Sensus.6	2	===== 1 2 3 4 5 6 7 . 8 9
x0.01	Sensus.5	2	===== 1 2 3 4 5 6 7 . 8 9
x0.01	Sensus.4	2	===== 1 2 3 4 5 6 7 . 8 9

Multiplier	Protocol	Truncate	AMI & Display
x0.001	Sensus.9	2	NOT VALID
x0.001	Sensus.8 Neptune.8	2	NOT VALID
x0.001	Sensus.7	2	===== 1 2 3 4 5 6 . 7 8 9
x0.001	Sensus.6	2	===== 1 2 3 4 5 6 . 7 8 9
x0.001	Sensus.5	2	===== 1 2 3 4 5 6 . 7 8 9
x0.001	Sensus.4	2	===== 1 2 3 4 5 6 . 7 8 9

Multiplier	Protocol	Truncate	AMI & Display
x0.0001	Sensus.9	2	NOT VALID
x0.0001	Sensus.8 Neptune.8	2	NOT VALID
x0.0001	Sensus.7	2	===== 1 2 3 4 5 . 6 7 8 9
x0.0001	Sensus.6	2	===== 1 2 3 4 5 . 6 7 8 9
x0.0001	Sensus.5	2	===== 1 2 3 4 5 . 6 7 8 9
x0.0001	Sensus.4	2	===== 1 2 3 4 5 . 6 7 8 9

Multiplier	Protocol	Truncate	AMI & Display
x0.1	Sensus.9	3	NOT VALID
x0.1	Sensus.8 Neptune.8	3	NOT VALID
x0.1	Sensus.7	3	NOT VALID
x0.1	Sensus.6	3	===== 1 2 3 4 5 6 7 8 . 9
x0.1	Sensus.5	3	===== 1 2 3 4 5 6 7 8 . 9
x0.1	Sensus.4	3	===== 1 2 3 4 5 6 7 8 . 9

Multiplier	Protocol	Truncate	AMI & Display
x0.01	Sensus.9	3	NOT VALID
x0.01	Sensus.8 Neptune.8	3	NOT VALID
x0.01	Sensus.7	3	NOT VALID
x0.01	Sensus.6	3	===== 1 2 3 4 5 6 7 . 8 9
x0.01	Sensus.5	3	===== 1 2 3 4 5 6 7 . 8 9
x0.01	Sensus.4	3	===== 1 2 3 4 5 6 7 . 8 9

Multiplier	Protocol	Truncate	AMI & Display
x0.001	Sensus.9	3	NOT VALID
x0.001	Sensus.8 Neptune.8	3	NOT VALID
x0.001	Sensus.7	3	NOT VALID
x0.001	Sensus.6	3	===== 1 2 3 4 5 6 . 7 8 9
x0.001	Sensus.5	3	===== 1 2 3 4 5 6 . 7 8 9
x0.001	Sensus.4	3	===== 1 2 3 4 5 6 . 7 8 9

Multiplier	Protocol	Truncate	AMI & Display
x0.0001	Sensus.9	3	NOT VALID
x0.0001	Sensus.8 Neptune.8	3	NOT VALID
x0.0001	Sensus.7	3	NOT VALID
x0.0001	Sensus.6	3	===== 1 2 3 4 5 . 6 7 8 9
x0.0001	Sensus.5	3	===== 1 2 3 4 5 . 6 7 8 9
x0.0001	Sensus.4	3	===== 1 2 3 4 5 . 6 7 8 9